

# Product datasheet

Specifications



## variable speed drive - 1.5kW- 400V - 3 phases - ATV340 Ethernet

ATV340U15N4E

### Main

Range of product	Altivar Machine ATV340
product or component type	Variable speed drive
Product specific application	Machine
variant	Standard version
mounting mode	Cabinet mount
Communication port protocol	Modbus serial EtherNet/IP Modbus TCP
Network number of phases	3 phases
Supply frequency	50...60 Hz +/- 5 %
[Us] rated supply voltage	380...480 V - 15...10 %
Nominal output current	4.0 A
Motor power kW	2.2 kW for normal duty 1.5 kW for heavy duty
Motor power hp	3 hp for normal duty 2 hp for heavy duty
EMC filter	Class C3 EMC filter integrated
IP degree of protection	IP20

### Complementary

Discrete input number	5
Discrete input type	PTI programmable as pulse input: 0...30 kHz, 24 V DC (30 V) DI1...DI5 safe torque off, 24 V DC (30 V), impedance: 3.5 kOhm programmable
number of preset speeds	16 preset speeds
Discrete output number	2.0
Discrete output type	Programmable output DQ1, DQ2 30 V DC 100 mA
Analogue input number	2
Analogue input type	A11 software-configurable current: 0...20 mA, impedance: 250 Ohm, resolution 12 bits A11 software-configurable temperature probe or water level sensor A11 software-configurable voltage: 0...10 V DC, impedance: 31.5 kOhm, resolution 12 bits A12 software-configurable voltage: - 10...10 V DC, impedance: 31.5 kOhm, resolution 12 bits
Analogue output number	1

<b>Analogue output type</b>	Software-configurable voltage AQ1: 0...10 V DC impedance 470 Ohm, resolution 10 bits Software-configurable current AQ1: 0...20 mA impedance 500 Ohm, resolution 10 bits
<b>Relay output number</b>	2
<b>Output voltage</b>	<= power supply voltage
<b>Relay output type</b>	Relay outputs R1A Relay outputs R1C electrical durability 100000 cycles Relay outputs R2A Relay outputs R2C electrical durability 100000 cycles
<b>Maximum switching current</b>	Relay output R1C on resistive load, cos phi = 1: 3 A at 250 V AC Relay output R1C on resistive load, cos phi = 1: 3 A at 30 V DC Relay output R1C on inductive load, cos phi = 0.4 and L/R = 7 ms: 2 A at 250 V AC Relay output R1C on inductive load, cos phi = 0.4 and L/R = 7 ms: 2 A at 30 V DC Relay output R2C on resistive load, cos phi = 1: 5 A at 250 V AC Relay output R2C on resistive load, cos phi = 1: 5 A at 30 V DC Relay output R2C on inductive load, cos phi = 0.4 and L/R = 7 ms: 2 A at 250 V AC Relay output R2C on inductive load, cos phi = 0.4 and L/R = 7 ms: 2 A at 30 V DC
<b>Minimum switching current</b>	Relay output R1B: 5 mA at 24 V DC Relay output R2C: 5 mA at 24 V DC
<b>Physical interface</b>	2-wire RS 485
<b>Connector type</b>	3 RJ45
<b>Method of access</b>	Slave Modbus RTU Slave Modbus TCP
<b>Transmission rate</b>	4.8 kbit/s 9.6 kbit/s 19.2 kbit/s 38.4 kbit/s
<b>Transmission frame</b>	RTU
<b>Number of addresses</b>	1...247
<b>Data format</b>	8 bits, configurable odd, even or no parity
<b>Type of polarization</b>	No impedance
<b>4 quadrant operation possible</b>	True
<b>Asynchronous motor control profile</b>	Constant torque standard Optimized torque mode Variable torque standard
<b>Synchronous motor control profile</b>	Permanent magnet motor Reluctance motor
<b>Pollution degree</b>	2 conforming to IEC 61800-5-1
<b>Maximum output frequency</b>	0.599 kHz
<b>Acceleration and deceleration ramps</b>	Linear adjustable separately from 0.01...9999 s S, U or customized
<b>Motor slip compensation</b>	Adjustable Not available in permanent magnet motor law Can be suppressed Automatic whatever the load
<b>Switching frequency</b>	2...16 kHz adjustable 8...16 kHz with derating factor
<b>Nominal switching frequency</b>	4 kHz
<b>Braking to standstill</b>	By DC injection
<b>Brake chopper integrated</b>	True
<b>Line current</b>	5.1 A at 380 V (normal duty) 4.1 A at 480 V (normal duty) 6.0 A at 380 V (heavy duty) 4.9 A at 480 V (heavy duty)

<b>Line current</b>	6 A at 380 V without line choke (heavy duty) 4.9 A at 480 V without line choke (heavy duty) 5.1 A at 380 V with external line choke (normal duty) 4.1 A at 480 V with external line choke (normal duty) 3.5 A at 380 V with external line choke (heavy duty) 2.8 A at 480 V with external line choke (heavy duty)
<b>Maximum input current</b>	6.0 A
<b>Maximum output voltage</b>	480 V
<b>Apparent power</b>	3.8 kVA at 480 V (normal duty) 4.1 kVA at 480 V (heavy duty)
<b>Maximum transient current</b>	6.2 A during 60 s (normal duty) 6 A during 60 s (heavy duty) 7.6 A during 2 s (normal duty) 7.2 A during 2 s (heavy duty)
<b>Electrical connection</b>	Screw terminal, clamping capacity: 1.5...4 mm <sup>2</sup> for line side Screw terminal, clamping capacity: 4...6 mm <sup>2</sup> for DC bus Screw terminal, clamping capacity: 1.5...4 mm <sup>2</sup> for motor Screw terminal, clamping capacity: 0.2...2.5 mm <sup>2</sup> for control
<b>Prospective line I<sub>sc</sub></b>	5 kA
<b>Base load current at high overload</b>	4.0 A
<b>Base load current at low overload</b>	5.6 A
<b>Power dissipation in W</b>	Natural convection: 46 W at 380 V, switching frequency 4 kHz (heavy duty) Forced convection: 46 W at 380 V, switching frequency 4 kHz (heavy duty) Natural convection: 59 W at 380 V, switching frequency 4 kHz (normal duty) Forced convection: 59 W at 380 V, switching frequency 4 kHz (normal duty)
<b>Electrical connection</b>	Line side: screw terminal 1.5...4 mm <sup>2</sup> /AWG 14...AWG 12 DC bus: screw terminal 4...6 mm <sup>2</sup> /AWG 12...AWG 10 Motor: screw terminal 1.5...4 mm <sup>2</sup> /AWG 14...AWG 12 Control: screw terminal 0.2...2.5 mm <sup>2</sup> /AWG 24...AWG 12
<b>With safety function Safely Limited Speed (SLS)</b>	True
<b>With safety function Safe brake management (SBC/SBT)</b>	True
<b>With safety function Safe Operating Stop (SOS)</b>	False
<b>With safety function Safe Position (SP)</b>	False
<b>With safety function Safe programmable logic</b>	False
<b>With safety function Safe Speed Monitor (SSM)</b>	False
<b>With safety function Safe Stop 1 (SS1)</b>	True
<b>With sft fct Safe Stop 2 (SS2)</b>	False
<b>With safety function Safe torque off (STO)</b>	True
<b>With safety function Safely Limited Position (SLP)</b>	False
<b>With safety function Safe Direction (SDI)</b>	False

<b>Protection type</b>	Thermal protection: motor Safe torque off: motor Motor phase loss: motor Thermal protection: drive Safe torque off: drive Overheating: drive Overcurrent: drive Output overcurrent between motor phase and earth: drive Output overcurrent between motor phases: drive Short-circuit between motor phase and earth: drive Short-circuit between motor phases: drive Motor phase loss: drive DC Bus overvoltage: drive Line supply overvoltage: drive Line supply undervoltage: drive Input supply loss: drive Exceeding limit speed: drive Break on the control circuit: drive
<b>Width</b>	85.0 mm
<b>Height</b>	270.0 mm
<b>Depth</b>	232.5 mm
<b>net weight</b>	1.7 kg
<b>Continuous output current</b>	5.6 A at 4 kHz for normal duty 4 A at 4 kHz for heavy duty

## Environment

<b>Operating altitude</b>	<= 3000 m with current derating above 1000m
<b>Operating position</b>	Vertical +/- 10 degree
<b>Product certifications</b>	UL CSA TÜV EAC CTick
<b>marking</b>	CE
<b>Standards</b>	IEC 61800-3 IEC 61800-5-1 IEC 60721-3 IEC 61508 IEC 13849-1 UL 618000-5-1 UL 508C
<b>Assembly style</b>	With heat sink
<b>Electromagnetic compatibility</b>	Electrostatic discharge immunity test level 3 conforming to IEC 61000-4-2 Radiated radio-frequency electromagnetic field immunity test level 3 conforming to IEC 61000-4-3 Electrical fast transient/burst immunity test level 4 conforming to IEC 61000-4-4 1.2/50 µs - 8/20 µs surge immunity test level 3 conforming to IEC 61000-4-5 Conducted radio-frequency immunity test level 3 conforming to IEC 61000-4-6
<b>Environmental class (during operation)</b>	Class 3C3 according to IEC 60721-3-3 Class 3S3 according to IEC 60721-3-3
<b>Maximum acceleration under shock impact (during operation)</b>	70 m/s <sup>2</sup> at 22 ms
<b>Maximum acceleration under vibrational stress (during operation)</b>	5 m/s <sup>2</sup> at 9...200 Hz
<b>Maximum deflection under vibratory load (during operation)</b>	1.5 mm at 2...9 Hz
<b>Permitted relative humidity (during operation)</b>	Class 3K5 according to EN 60721-3
<b>Volume of cooling air</b>	18.0 m <sup>3</sup> /h
<b>Type of cooling</b>	Forced convection
<b>Overvoltage category</b>	Class III

<b>Regulation loop</b>	Adjustable PID regulator
<b>Noise level</b>	55.4 dB
<b>Pollution degree</b>	2
<b>Ambient air transport temperature</b>	-40...70 °C
<b>Ambient air temperature for operation</b>	-15...50 °C without derating (vertical position) 50...60 °C with derating factor (vertical position)
<b>Ambient air temperature for storage</b>	-40...70 °C
<b>Isolation</b>	Between power and control terminals

## Packing Units

<b>Unit Type of Package 1</b>	PCE
<b>Number of Units in Package 1</b>	1
<b>Package 1 Height</b>	11.000 cm
<b>Package 1 Width</b>	37.000 cm
<b>Package 1 Length</b>	32.000 cm
<b>Package 1 Weight</b>	2.480 kg
<b>Unit Type of Package 2</b>	P06
<b>Number of Units in Package 2</b>	14
<b>Package 2 Height</b>	75.000 cm
<b>Package 2 Width</b>	60.000 cm
<b>Package 2 Length</b>	80.000 cm
<b>Package 2 Weight</b>	47.720 kg

## Sustainability

**Green Premium™ label** is Schneider Electric's commitment to delivering products with best-in-class environmental performance. Green Premium promises compliance with the latest regulations, transparency on environmental impacts, as well as circular and low-CO<sub>2</sub> products.

**Guide to assessing product sustainability** is a white paper that clarifies global eco-label standards and how to interpret environmental declarations.

[Learn more about Green Premium >](#)

[Guide to assess a product's sustainability >](#)



Transparency RoHS/REACH

## Resource performance

Upgraded Components Available

## Well-being performance

Mercury Free

Rohs Exemption Information Yes

## Certifications & Standards

**Reach Regulation** [REACH Declaration](#)

**Eu Rohs Directive** Pro-active compliance (Product out of EU RoHS legal scope)

**China Rohs Regulation** [China RoHS declaration](#)

**Environmental Disclosure** [Product Environmental Profile](#)

**Weee** The product must be disposed on European Union markets following specific waste collection and never end up in rubbish bins

**Circularity Profile** [End of Life Information](#)

Dimensions Drawings

Dimensions

---

Views: Front - Left - Rear

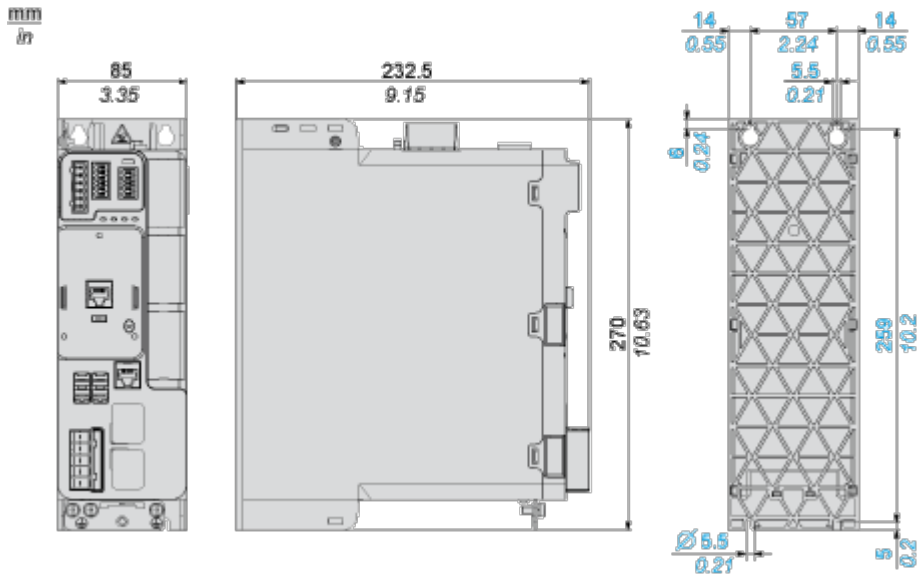

Mounting and Clearance

Clearance

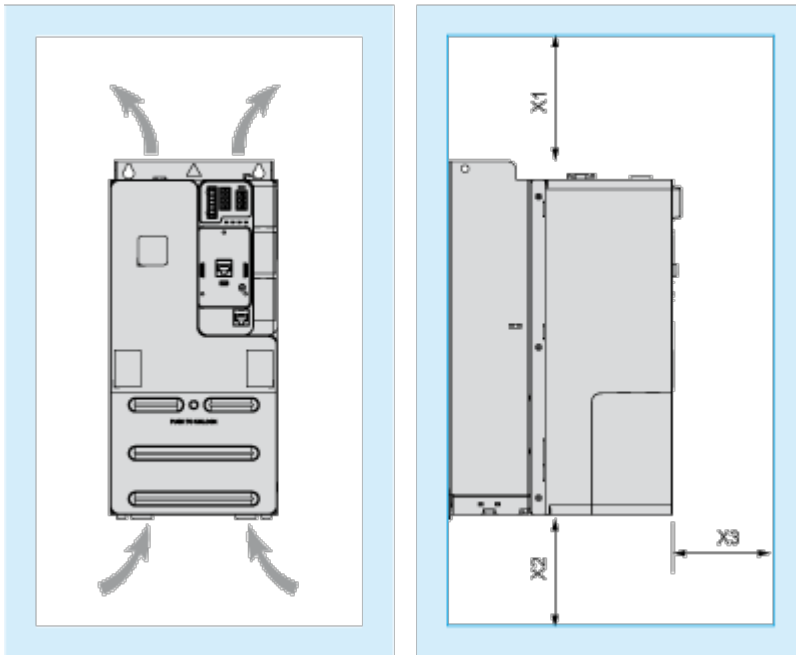

Dimensions in mm

X1	X2	X3
≅ 100	≅ 100	≅ 60

Dimensions in in.

X1	X2	X3
≅ 3.94	≅ 3.94	≅ 2.36



**Mounting Types**

---

**Mounting Type A: Side by Side IP20**

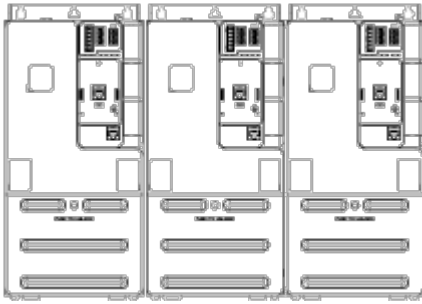

Possible, at ambient temperature  $\leq 50\text{ }^{\circ}\text{C}$  (122  $^{\circ}\text{F}$ )

**Mounting Type B: Individual IP20**

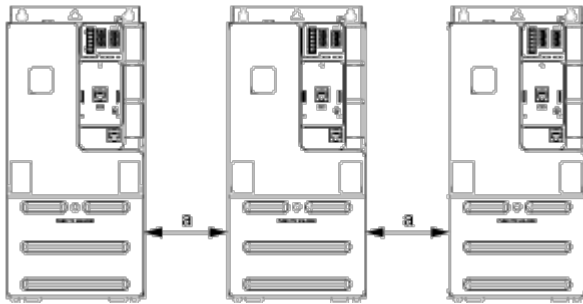

a  50 mm (1.97 in.) from 50...60 $^{\circ}\text{C}$ , no restriction below 50 $^{\circ}\text{C}$

Connections and Schema

Connections and Schema

Three-phase Power Supply with Upstream Breaking via Line Contactor Without Safety Function STO

Connection diagrams conforming to standards ISO13849 category 1 and IEC/EN 61508 capacity SIL1, stopping category 0 in accordance with standard IEC/EN 60204-1.

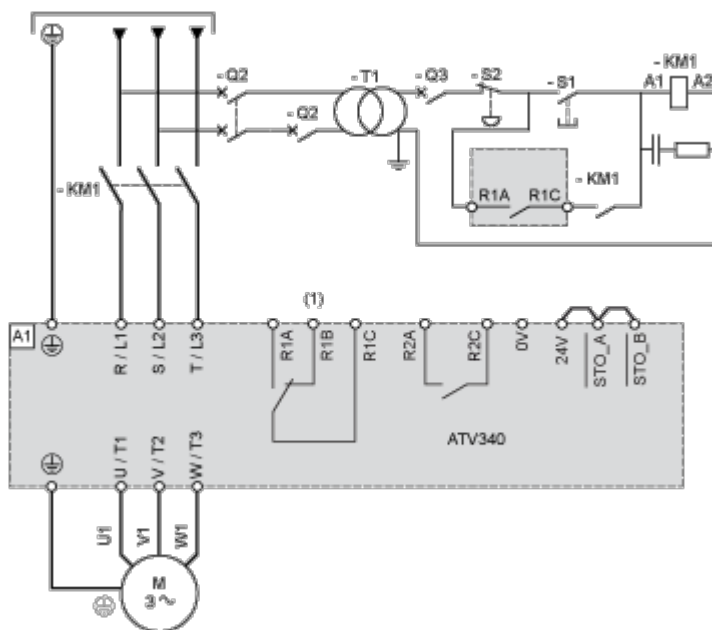

(1) Use relay output R1 set to operating state Fault to switch Off the product once an error is detected.

A1 : Drive

KM1 : Line Contactor

Q2, Q3 : Circuit breakers

S1 : Pushbutton

S2 : Emergency stop

T1 : Transformer for control part

Three-phase Power Supply With Downstream Breaking via Switch Disconnecter

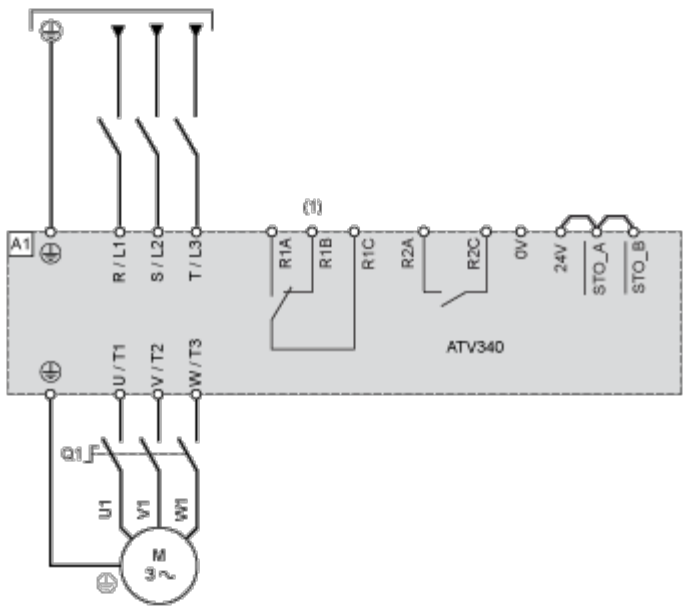

(1) Use relay output R1 set to operating state Fault to switch Off the product once an error is detected.

A1 : Drive

Q1 : Switch disconnect

**Sensor Connection**

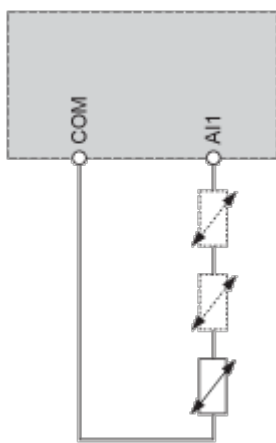

It is possible to connect either 1 or 3 sensors on terminals AI1.

Control Block Wiring Diagram

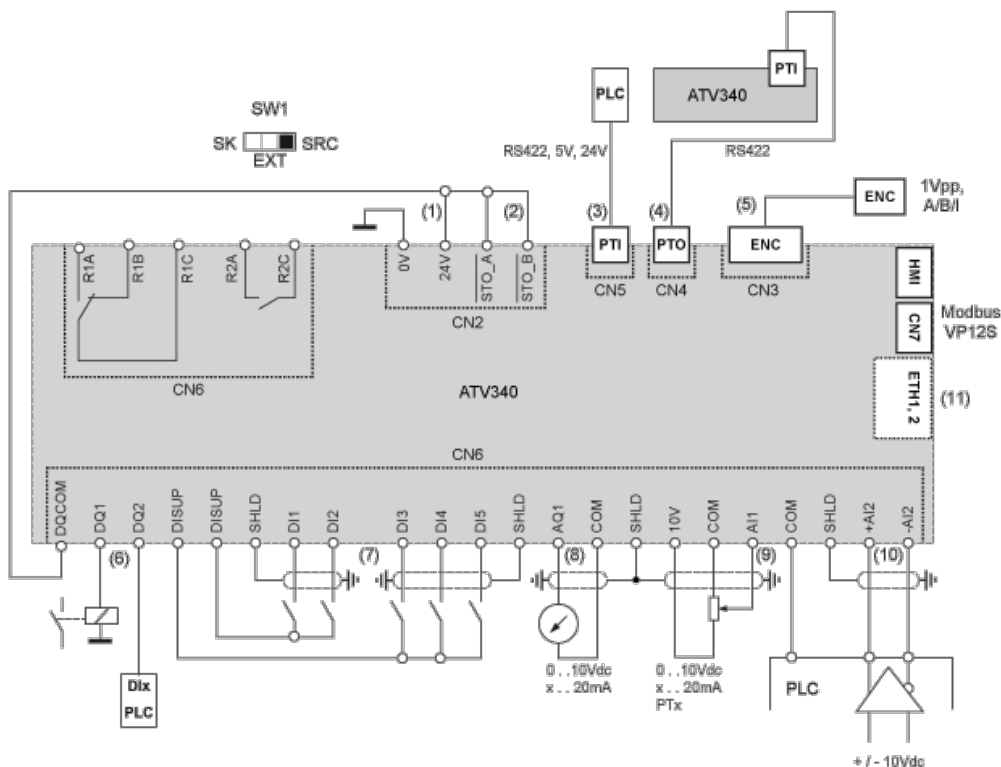

- (1) 24V supply (STO)
- (2) STO - Safe Torque Off
- (3) PTI - Pulse Train In
- (4) PTO - Pulse Train Out
- (5) Motor Encoder connection
- (6) Digital outputs
- (7) Digital inputs
- (8) Analog output
- (9) Analog input
- (10) Differential Analog Input
- (11) Ethernet port (only on Ethernet drive version)

SW1 : Sink/Source switch

R1A, R1B, R1C : Fault relay

R2A, R2C : Sequence relay

Digital Inputs Wiring

Digital Inputs: Internal Supply

Using DISUP Signal

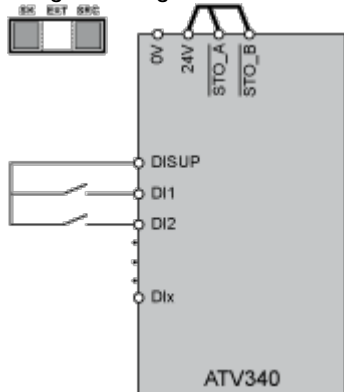

In SRC position DISUP outputs 24 V. In SK position DISUP is connected to 0 V.

Digital Inputs: External Supply

Positive Logic, Source, European Style

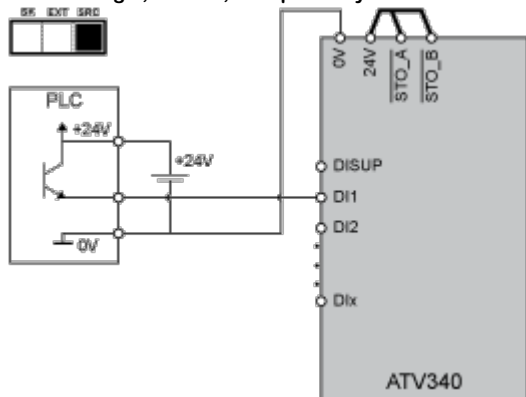

Negative Logic, Sink, Asian Style

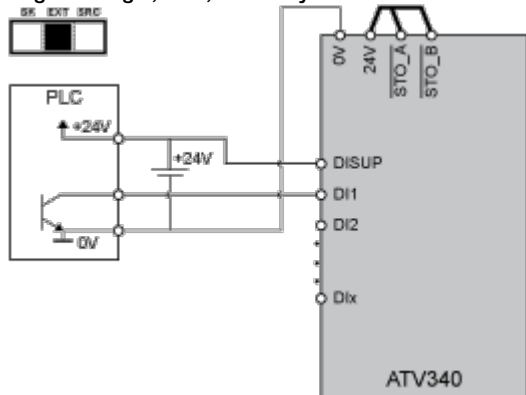

Digital Inputs: Internal supply

Negative Logic, Sink, Asian Style

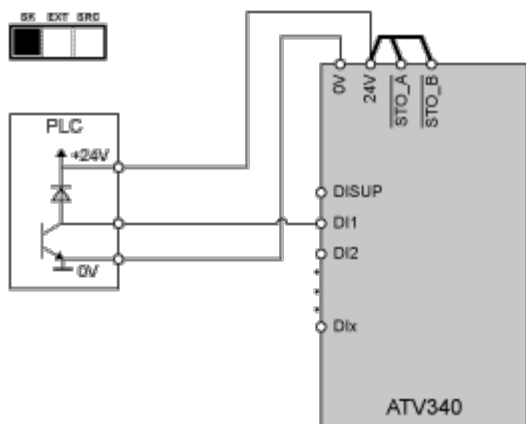

Digital Outputs Wiring

---

Digital Outputs: Internal Supply

Positive Logic, Source, European Style, DQCOM to +24V

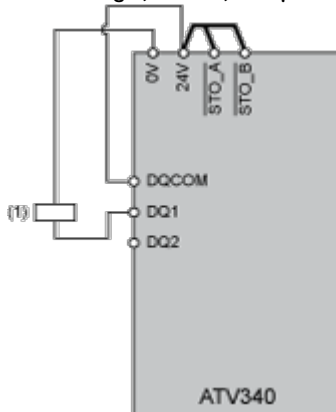

(1) Relay or valve

Negative Logic, Sink, Asian Style, DQCOM to 0V

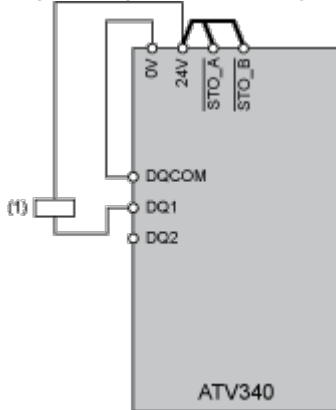

(1) Relay or valve

Digital Outputs: External Supply

Positive Logic, Source, European Style, DQCOM to +24V

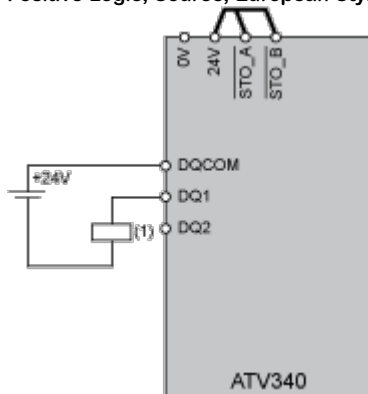

(1) Relay or valve

Negative Logic, Sink, Asian Style, DQCOM to 0V



(1) Relay or valve



Performance Curves

Open Loop Applications

---

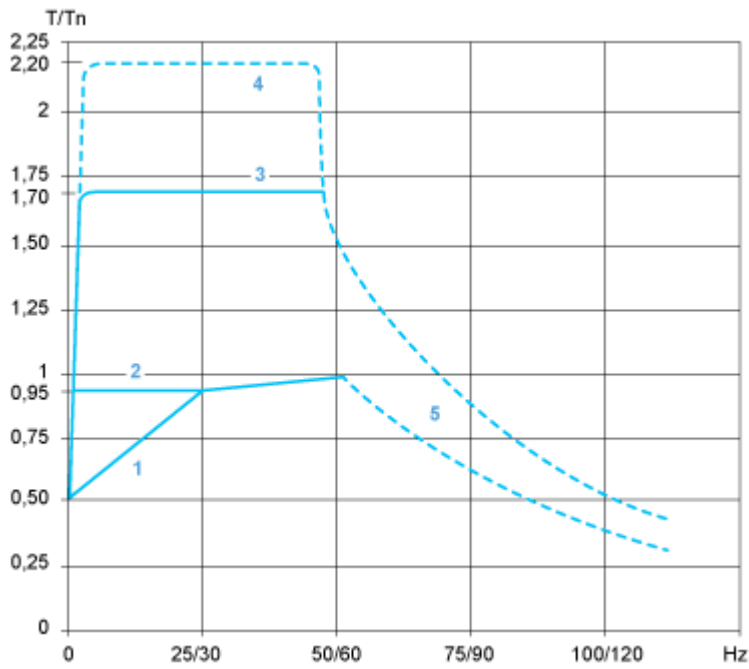

- 1 : Self-cooled motor: continuous useful torque
- 2 : Force-cooled motor: continuous useful torque
- 3 : Overtorque for 60 s maximum
- 4 : Transient overtorque for 2 s maximum
- 5 : Torque in overspeed at constant power

Closed Loop Applications

---

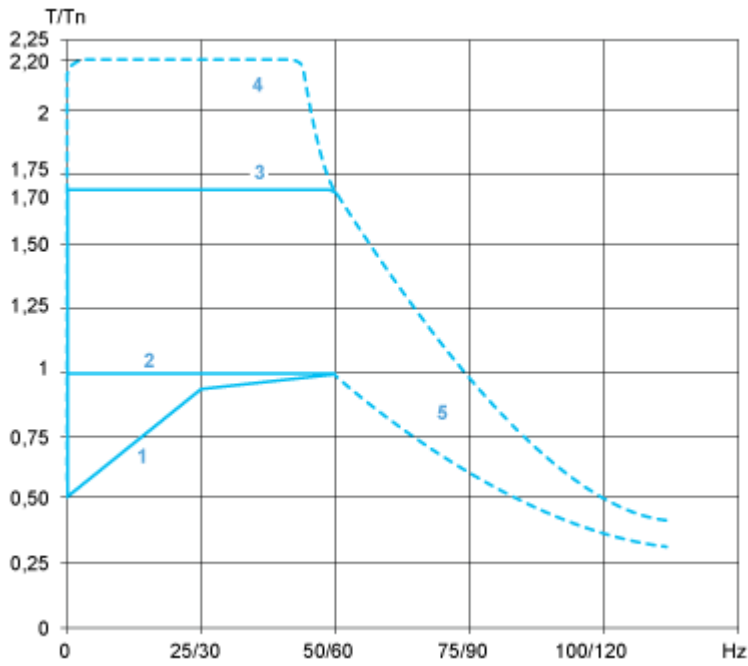

- 1 : Self-cooled motor: continuous useful torque
- 2 : Force-cooled motor: continuous useful torque
- 3 : Overtorque for 60 s maximum
- 4 : Transient overtorque for 2 s maximum
- 5 : Torque in overspeed at constant power